

Exploratory study on a segmented shell made of recycled-HDPE plastic

Francesco LACCONE*, Iason MANOLAS^{a,b}, Luigi MALOMO^a, Paolo CIGNONI^a

* ISTI - CNR
via Giuseppe Moruzzi 1, 56124 Pisa, Italy
francesco.lacone@isti.cnr.it

^a ISTI – CNR

^b Department of Computer Science - University of Pisa

Abstract

Recycled HDPE plastic can be obtained from up to 100% waste material and can be produced in the shape of panels and rods. The aim of this work is to explore the possibility to employ this material for structural purposes. The proposed concept for segmented shells is based on the cassette system, namely a spatial waffle structure clamped by inner and outer plates, and a shaping strategy of the shell cross section targeted on bending. The concept is applied on translational surfaces, in which the transverse cross section serves as the shaping objective. A digital workflow is implemented to explore the possible solutions and to evaluate the shells' feasibility from both a fabrication and a structural point of view. A case study of 5.2 meters is further explored with nonlinear analysis.

Keywords: conceptual design, construction systems, segmented shell, recycled polyethylene, structural design, dry-assembly, bending, non-funicular.

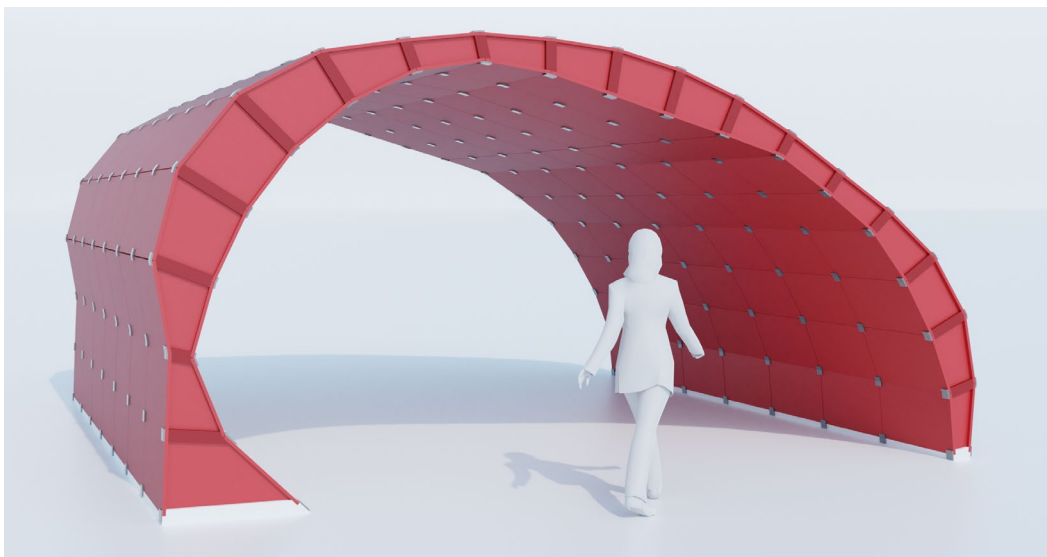

Figure 1: A segmented pavilion made of recycled-HDPE

1. Introduction

Using recycled building materials is one of the possible actions to reduce the carbon footprint in construction process. Although the traditional building industry, unlike other markets, is still far from a complete energy transition, non-conventional materials are becoming more performing and can be therefore applied also in architectural contexts. High-density polyethylene (HDPE) is a thermoplastic polymer that has been already used for furniture and wall covering and can be produced from up to 100% recycled material. This material presents good mechanical and chemical properties, such as good strength and stiffness, and UV-stability respectively. Moreover, it is characterized by a wide range of service temperature (from about -250 to 80° C). HDPE is basically fabricated in the form of bi-dimensional flat panels or tubes. The technological advantages of using these elements include the possibility of milling, sawing and, in general, to fabricate them with relatively low-cost manufacturing, i.e. using the same tools and machines employed for timber.

Despite all these advantages, the load bearing potential of this material is still unexplored. Thus, the objective of this research is to design a shell made of recycled HDPE. To manufacture curved structures, the panels can be either bent or segmented in order to produce a faceted surface. A good concept for segmented shells consists of assembling together hollow box elements, made of a top plate with side plates, to eventually obtain a ribbed structure that is very stiff and lightweight. Such approach has been successfully applied in timber construction.

The shape adopted for testing this concept is a translational surface, formed by a free-form curve that moves along a straight path. A hollow-box segmented shell is obtained by discretizing longitudinally and transversally this surface. In the transverse direction, the structural cross section is shaped by varying its thickness, based on the bending stress calculated on a beam with the same shape and submitted to a uniformly distributed loading. So the section thickness along the normal is large if the bending moment is large and vice versa. The design and fabrication pursue the concept of a complete dry-assembly of the structure to guarantee a simple and reversible construction phase.

2. Related work

2.1. Hollow box (waffle) design

Shells are structural surface elements that are shaped in 3D and transfer the external load to the supports predominantly through membrane forces, i.e. which act in plane. Shape design and form-finding can reduce the bending force acting on a shell. However, even though the shape is optimal from this point of view, bending resistance is needed at least to prevent buckling (Adriaenssens *et al.* [1]).

Nowadays, it is common practice to discretize shells' continuous surface in fabricable entities in order to reduce costs, increasing the prefabrication grade and the precision, and speeding-up the assembly phase. Thus, structural concepts such as grid shells (Douthe *et al.* [5], Grande *et al.* [7], Laccone *et al.* [10], Pellis and Pottmann [13]) and plate shells (Bagger [2]) have increased the variety of shell types. In these structures, membrane forces flow through grids of rods and polyhedral surfaces respectively. On the other hand, in such lattice structures bending resistance can be obtained only by tuning the bending stiffness of joints.

To reduce the complexity of the joints to a minimum and simultaneously address bending resistance demands, alternative concepts of double-layer shells and hollow-box shells can be adopted. In double layer shells the load bearing is realized by two interconnected surfaces. Still, they can be segmented, and shaped i.e. as grids, as plates etc. Box shells instead rely on generating bending resistance from the use of members with an increased inertia in the out of plane. For instance, if a grid of quads is used to initialize it, this approach generates an array of hollow boxes organized in a *waffle structure* (as in the Serpentine Pavilion by Alvaro Siza and Eduardo Souto de Moura).

Hollow box (alternatively, *cassette* or *waffle*) structures are typically made out of timber. They benefit from a relatively simple connectivity between the pieces and from the opportunity of automating part of the manufacturing process through CNC machines. Indeed, if analyzed merely from a fabrication point of view, the waffle structure appears as one of the most widespread techniques and constitutes a simple strategy to define volumetric object by means of planar element (e.g., the Metropol Parasol, Seville).

A fundamental reference is constituted by the work done in the Laboratory for Timber Constructions (IBOIS) of EPFL (Robeller *et al.* [18], Rad *et al.* [15]) on a lightweight construction system for doubly-curved shells made of two layers of timber. The pieces are dry-connected through integral through-tenon joints carved with 5-axis CNC milling machine, and use no glue nor screws. The segmentation of the surface considers fabrication requirements as well as structural behavior.

The BUGA Pavilion is an additional paradigmatic example of a timber segmented shell that spans 30 meters (Bechert *et al.* [3], Sonntag *et al.* [20]). This structure is made of wood submodules realized as hollow cassettes. Each of them is a block built up of two polygonal plates, namely top and bottom face of the shell, that clamp a ring of beams arranged on the border of this block. The bottom plate has a large opening, which facilitate the assembly operations and inspections.

2.2. Plastic-based architecture

Plastics are artificial materials that can be produced in different ways and can have different properties, therefore they can be found in various shapes and applications. Applications in architecture have been rather rare up to the '40s, in which part of the engineering and industrial knowledge in realizing airplanes, cars and boats has been applied to architectural prototyping. In this period building construction adopted a mass production intent, and thus several prototypes of plastic houses with their futuristic language were introduced. The Monsanto House of the Future (designed by Marvin Goody and Richard Hamilton) and the Futuro House (designed by Matti Suuronen) are only two examples of them.

Among other factors, the energy crisis of the '70s has limited the spread of such mass-produced object (Engelsmann *et al.* [6]). However, plastic components remain still commonly in use in our buildings, in the form of façade panels and cladding, insulating material, fittings and as material for retrofitting load-bearing components, e.g. fibre-reinforced plastics. Nowadays, the objective of sustainable development has brought designers to critically rethink the use of these materials. It can be declined on the one hand on limiting the production of new products from oil and substituting them with bio-based products, and on the other hand on recycling dismissed components or waste material. Particularly, on this latter scheme several strategies took place in the building industry, such as the use of waste and recycled plastic materials in concrete mix (Gu and Togay [8]) and paving components.

Panels and rods can be produced out of a blend of virgin/recycled plastics and even out of recycled plastics entirely. High quality recycled plastics can be obtained from grinding and pelletizing waste material derived from industrial production and post-consumed material from the municipal solid waste. In the later case, further processes such as sorting, shredding, washing are required due to the presence of high impurities and contaminants in the input material, e.g. labels, adhesives, mud and dust (Rajendran *et al.* [16]). The recycled plastics can substitute the use of virgin construction materials and its percentage in the blend can alter some of the material properties (Pattanakul *et al.* [12], Ramírez-Vargas *et al.* [17], Miu *et al.* [11]).

Applications of components made of a blend virgin/recycled and 100% recycled plastics are to date restricted to home and outdoor furniture, fences etc. The right concentration of virgin material depends on the specific application and the desired performance. Moreover an important aspect of recycling polymers that requires additional investigation is the degradation of their properties with respect to the number of cycles as well as their operating conditions.

3. Design concept and methods

Plastics properties range in a broad spectrum of values, i.e. for thermal, chemical, mechanical, environmental features. For this reason, each product can be extremely specialized for its intended use. Concerning the mechanical characteristics, the majority of plastic materials have a low stiffness compared to other common structural materials. However, if a load-bearing function is required from plastic components, the strength lack can be filled with an accurate conceptual design that can be based for instance on the selection of an effective global shape, on the use of curved components, on shell or composite behavior and so on.

For the present work, two masterpieces of structural engineering have been selected as reference: the Berlin Central Station roof (designed by gmp Architekten and sbp) and Waterloo station roof in London, UK (designed by Grimshaw Architects and YRM Anthony Hunt Associates). Both structures adopt a planar arch frame that is replicated along the rail path to support a translational surface. The main arch line is stiffened by cables and along-normal struts, which are oriented inward or outward according to the bending moment pattern profile. This tension stiffening system can be considered as an added layer and it is usually post-tensioned until bending forces are removed and/or compressive forces on the main layer are preserved. This concept inspired research based on graphic statics aimed at transforming a free-form curve (non-funicular structure) into a funicular shape (BLOCK Research Group [4], Todisco *et al.* [21], Todisco *et al.* [22]).

3.1. Geometric and structural design

To comply with material capacity and fabrication constraints three main strategies are adopted in the structural concept:

- a spatial curved shape, in order to rely on an inherent form-rigidity;
- a cassette structure, to employ a combination of planar elements that are easy to fabricate, namely a waffle system plus inner and outer plates;
- and a bending-shaped profile, in order to achieve low stress on the elements and low displacements.

To assess the feasibility of a structure conceived according to these three points and to easily explore the design space through a suitable parametric workflow, single-curvature surfaces are adopted. Thus, the final structure could be discretized into plate elements, which are material- and fabrication-compliant.

In the present case, to reduce the problem complexity, a translational surface is assumed as target shape. In fact, similarly to the referenced work, the objective is to design a planar bending-shaped structural system that could be easily replicated in a linear array. If these planar systems are connected transversally, a waffle structure is obtained since both are flat curved panels. And finally the infill space can be enclosed with two plates to form a cassette structure. In bending-shaped structures made of unidimensional elements, a double layer of cables is usually associated with a main truss; conversely, in the present case the two layers are two equal-thickness plates. The bending plot is simply used to scale proportionally the distance between them, which involves contextually finding the cross-section height of the waffle plates.

This simple workflow is organized as in Fig. 2 and has been implemented into Rhinoceros and grasshopper environment [19] and uses Karamba3D [14] to run structural FE analyses. A final FE model is also developed in Straus7 [9]. As first step, an open NURBS curve is generated from a set of control points laying on a plane. Such curve is controlled through the points' location and can differ from an exact funicular line.

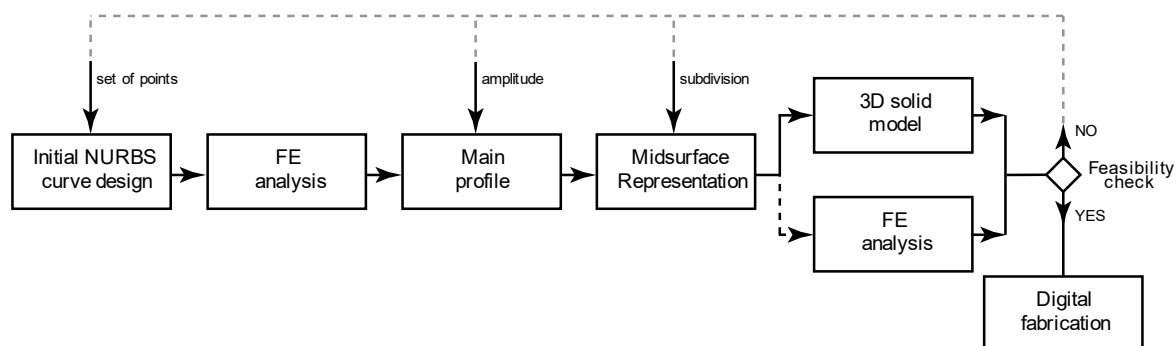

Figure 2: Flow chart adopted in the design and verification of the recycled-HDPE pavilion

This curve is transformed into a generic beam centerline with a constant cross section, and its end points are assumed as supports. The beam is loaded by a uniformly distributed vertical load. The linearity of the problem justifies the generic input properties. The FE analysis provides the bending moment plot, which could have any amplitude or sign (above or below the centerline, evidently), because whichever geometry or boundary condition can be applied as input. The centerline and the bending moment plot may be used to generate a planar surface. In the general case, these curves intersect at some points meaning that the bending moment is locally null, and thus would have been the cross-section as a consequence. However, a minimum height value h is set to ensure the flow of membrane forces. The amplitude of the main structure is adjusted based on two parameters: the minimum height value and a scale factor that is applied to the bending graph (Fig. 3). The assumption behind this strategy is that the stress caused by bending would be constant in inner and outer plates, as long as the beam boundary conditions are preserved.

For defining the waffle geometry, longitudinal and transversal resolutions have to be specified. The first is defined by the number of main structures to be replicated along the generatrix of the surface, the second by the number of subdivisions of the main structure into equal-length parts. Having fixed the resolution, the inner and outer plates that enclose the waffle geometry can be obtained as quad meshes straightforwardly.

All elements, modelled as plates, can be further processed to create a 3D model to verify the design feasibility, and can be linked to a new structural analysis setting, in which the strength and the rigidity of the solution is assessed. Eventually, the obtained solution can be further improved by acting on the design parameters or can be linked to a digital fabrication workflow and sent to production.

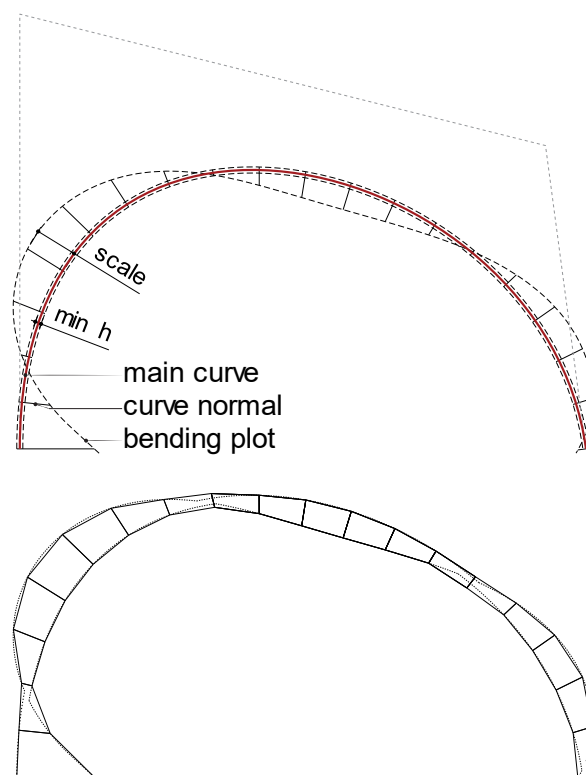

Figure 3: Parameters involved and genesis of the main structure

3.2. Connection preliminary design

All details are designed to be dry and reversible to speed up both the production and the assembly phase. The waffle plates are organized on a quad mesh layout and merged into four-ways nodes. The nodes are made from extruded square profiles made of the same recycled-HDPE material, and are carved longitudinally using T-shaped machine tools (Fig. 4). Thus, the incident waffle plates, which similarly present a milled vertical line, can simply be driven together along the guides provided on the node faces. Afterwards, the waffle plates are locked by clamping. The extremities of the node profile hosts a cross-shaped plate to restrain in-plane the corners of the inner and outer plates. The clamping system is fastened through a concentric threaded bar and two clamping plates. These latter need an edge connection to transfer bending stress.

The connection is expected to have a large influence on the stiffness. And it appears clear that the connection here proposed has been conceived for a shelter prototype with a low span submitted to a low loading scenario. To scale it up all necessary strengthening and stiffening strategies may be adopted, such as doubling the waffle plates, bracing the cassettes, stiffening the connections etc. Based on the size and loading scenario, a detailed experimental investigation has to be carried out to evaluate the feasibility, the necessary tolerances and the ideal assembly sequence of the modules.

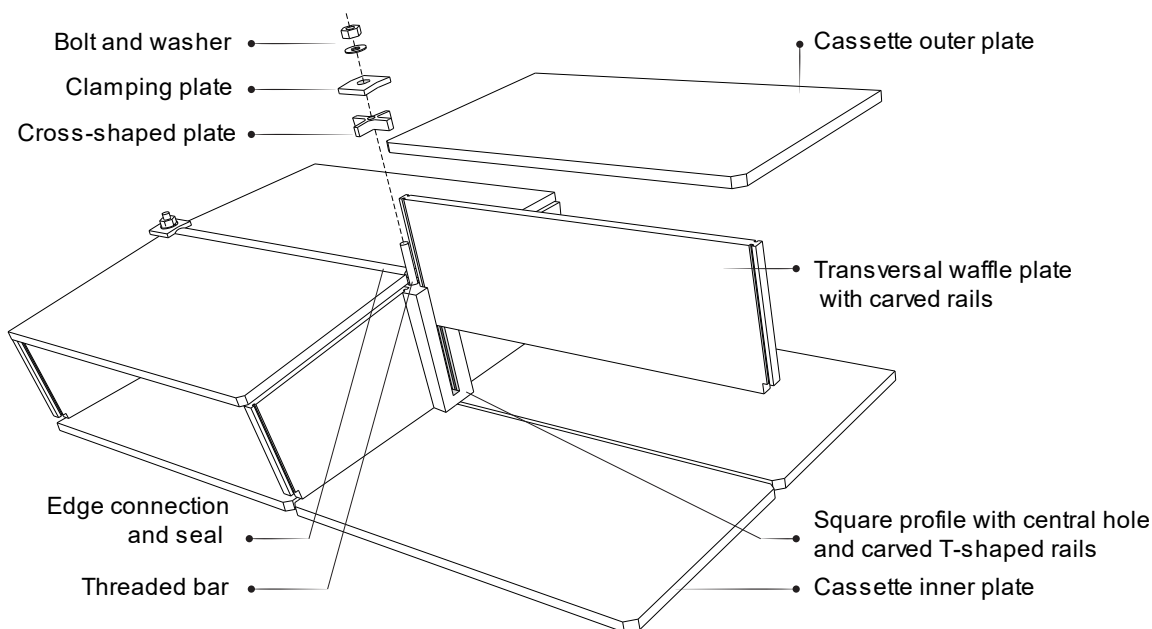

Figure 4: Connection exploded view

3.3. Material behavior and fabrication

High-density polyethylene (HDPE) is a thermoplastic polymer that has been already used for furniture and wall covering. It can be produced out of recycled material, which comes in form of granules. These are basically melted and processed in the form of bi-dimensional flat panels or tubes. This material presents good mechanical and chemical properties, such as good strength and stiffness, and UV-stability respectively. For the present work, characteristic values provided by manufacturer are used (Table 1). The use as a structural material can be limited by the low stiffness (compared to other materials) and the long term and environmental effects, which are matters that still require investigation. The declared softening temperature is 80°C.

The technological advantages of using these elements include the possibility of milling, sawing and, in general, to fabricate them with relatively low-cost manufacturing, i.e. using the same tools and CNC machines as the ones employed for timber.

Table 1: Mechanical properties of HDPE material adopted in the structural analysis.

Density (kg/m ³)	Young's modulus (N/mm ²)	Yield strength (N/mm ²)	Breaking Strain (%)
930	600	20	>50

4. Analysis and results

In the present work the design space of the problem has been explored manually. The workflow relies on a large number of parameters and it is possible to initialize only few of them to a tentative value. For instance, based on the initial FE results, the height of the waffle could be locally assumed as equal to the lever arm of the resisting moment developed by the in-plane forces of the inner and outer plates. Additionally, the longitudinal spacing could be sized based on the allowable in-plane force. Then, iterative changes of parameters are required until plausible geometries are obtained as well as acceptable strength and stiffness.

A large number of solutions in terms of geometry and statics can be produced for the main structure. In Fig. 5 some exemplary solutions have been reported. Red curves and dashed grey polylines point at the main NURBS curves and their control polygon respectively. Dashed black curves are the bounds of the cross-section geometry. It is worth mentioning that in zero-moment points usually relevant kinks are produced, which are accumulation points for stresses. Therefore, the shape is made smoother locally.

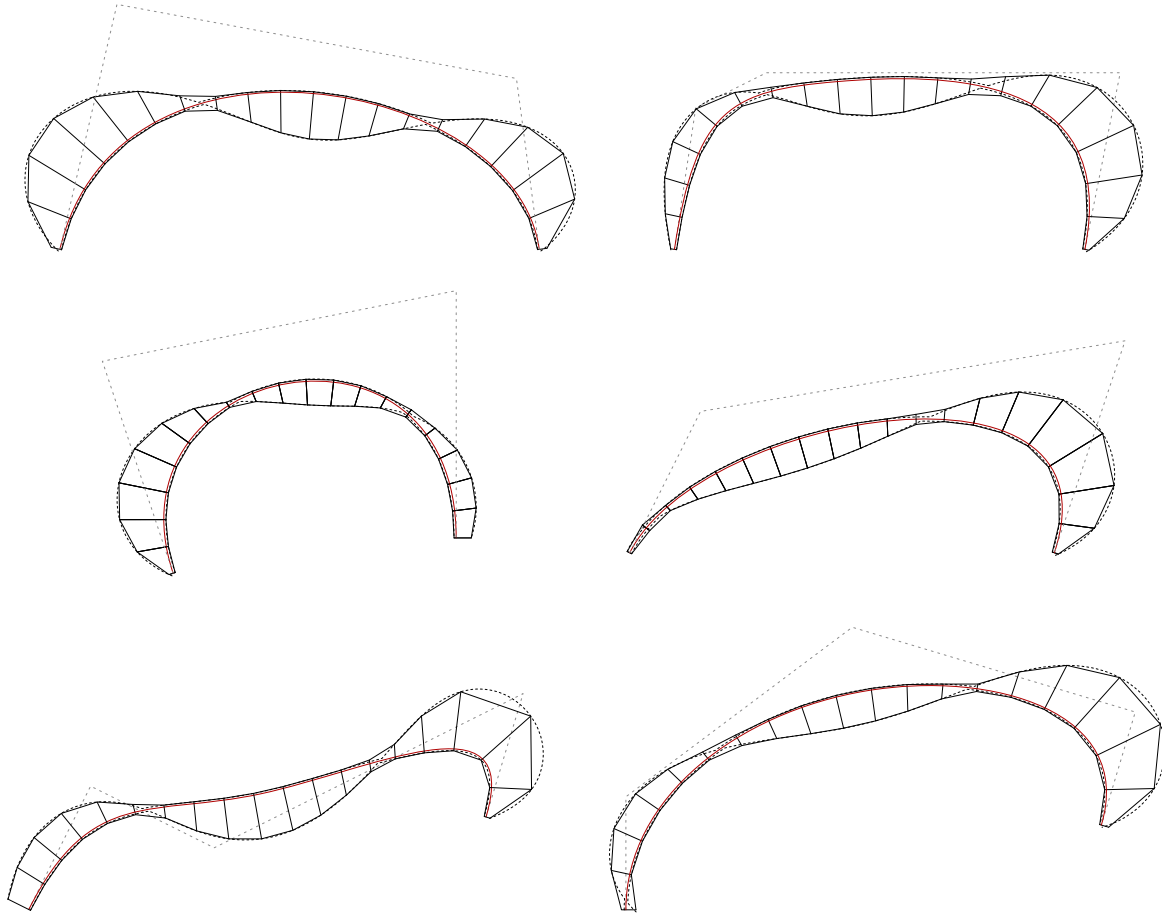

Figure 5: Design alternatives for the cross-section shape

The performances from a static viewpoint of all solutions have been assessed by means of a 3D analysis in Karamba3D. The detail of the model complies with the necessity of generating it from a parametric workflow. Therefore, some simplifications are introduced. Both waffle and cassette panels are discretized into FE plates of thickness $t = 2$ cm, the edges on the border are shared with the adjacent elements. The consequence is that the presence of the node is neglected and the link between the cassette plates and the waffle is stiffer than in the proposed detail. For the ground plates, x , y and z displacements are fixed. Apart from gravity, a vertical load of $q = 1$ kN/m² is applied (e.g., snow loading).

The target dimensions for the structures are in the range of 3-6 m. The cassette system appoints the structure an inherent stiffness; however the problem for the considered scenario is prevalently stiffness-based. The maximum displacement is then assumed as a control parameter. Besides the main profile shaping, the size of the cassette (namely the waffle grid) can be tuned to improve the stiffness. The shell ground nodes are fixed since the case studies are generated from beams with fixed endpoint.

All elements of the cassette system are strictly necessary to the statics of the structure. A simple hollow box system, made of only the waffle plates, would have been highly deformable in the in-plane direction and required additional elements to brace the cells.

As a proof of the results, some geometries, such as the shape of Fig. 3, have been exported and analyzed into Straus7 involving geometrical nonlinearities. This shape is generated from four-points NURBS curve, divided into 19 segments. The bending moment is computed using rigid boundary conditions. As a result, the distance between the cassette plates ranges from 10.5 cm to 76.7 cm. A rendered view of the shell is included in Fig. 6.

The deformation field at the SLS appears as in Fig. 7 (top), where the maximum displacement is 16.6 mm. Considering that the span is about $L = 5.2$ m, the design is fulfilled even using as limitation $L/250$. The map of von Mises stress (Fig. 7 bottom) shows that the utilization of the material is well within the strength limits (the maximum von Mises stress is 4.05 MPa at the ULS, while the tensile strength is 20 MPa). The highly stressed areas identify prevalently the compressed parts, where the effect of membrane forces are superimposed to the shrinkage caused by bending. The bending stress, in which part of the cross section is tensioned and part is compressed, is clearly visible from Fig. 8. Positive stress is located as expected from the bending plot: locally both the cassette plates and the neighboring sides of the waffle plates are tensioned. Vice versa for the negative stress.

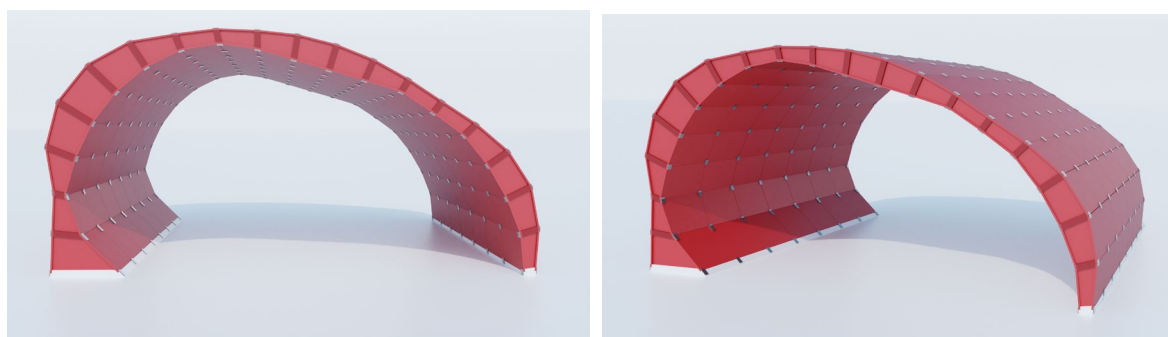

Figure 6: Case study

The opinion of the authors is that the current model underestimates some phenomena and overestimates some others, however the structure is verified with a certain safety margin. This is particularly important in light of the uncertainties introduced on one hand by the material behavior, which requires a better characterization, and on the other hand by the higher-level abstraction introduced in the modelling phase.. In detail, the modelling strategy here adopted has to be improved to include realistic connections on the waffle node and a more refined connectivity between the elements.

5. Conclusions

This work has addressed the design of segmented shells made of recycled-HDPE, which was, to the best of the authors knowledge, employed here for this purpose for the first time. The structural system here adopted consisted of the cassette structure, which is composed of a grid of plates that form a waffle structure in addition to inner and outer plates. The design objectives were: to achieve stiffness through geometry, because the material rigidity is not very high compared to other competitors; and to preserve low stress levels, because the material is not fully characterized from a structural point of view. This concept was applied to translational surfaces with various NURBS generatrices along a straight rail.

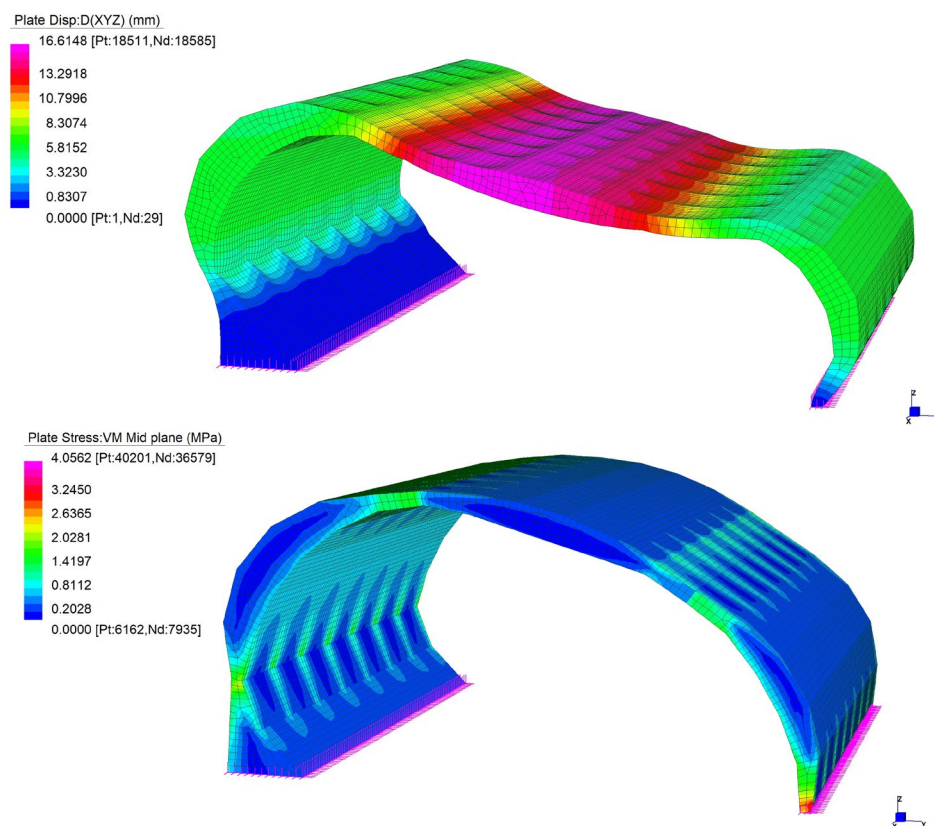

Figure 7: Case study results: top, magnified 15% SLS displacement; bottom, von Mises stress at ULS

The cross section of these shells has been shaped based on the bending moment computed on the generatrix, considered as a beam under its own weight. The design exploration has been assisted by a digital workflow, which has been developed to generate and control the geometry of the structure, and to assess its feasibility from both a statics and a constructional point of view.

The results show that several design alternatives are possible in the range of 3-6 meters. Therefore, the concept appears particularly suitable for temporary shelters. The nonlinear analysis performed on the case study demonstrates a maximum deflection that is below the 50% of the standard code limits, and a utilization rate of about 20% in terms of stress.

Even though further investigation of the recycled-HDPE material needs to be done, the preliminary results here gained appear promising. The cassette concept and the bending shaping have a broader validity as already demonstrated by multiple exemplars of wooden shells, and as a consequence can be extended to other structural materials and forms.

Acknowledgements

This research was partially funded by the EU H2020 Programme EVOCATION: Advanced Visual and Geometric Computing for 3D Capture, Display, and Fabrication (grant no. 813170).

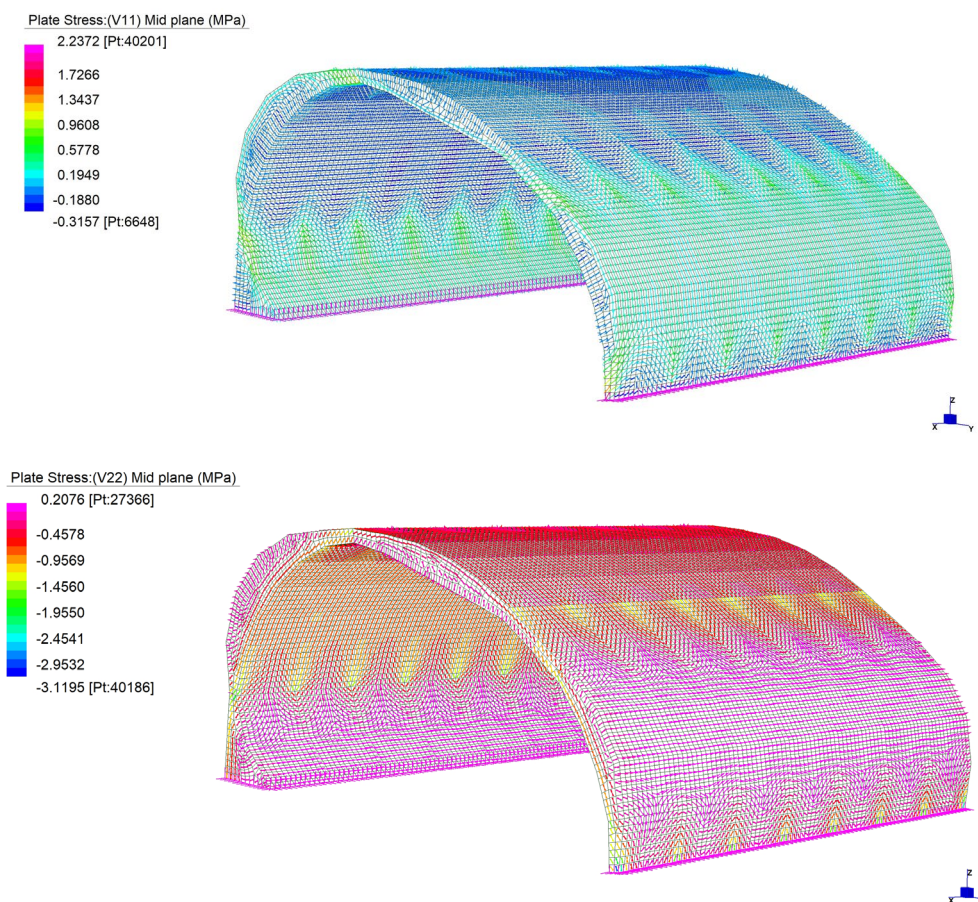

Figure 8: Case study results: left, max principal stress at ULS; right, min principal stress at ULS

References

- [1] Adriaenssens S., Block P., Veenendaal D., and Williams C., *Shell structures for architecture: form finding and optimization*, Routledge, 2014.
- [2] Bagger A. 2010. *Plate shell structures of glass: Studies leading to guidelines for structural design*. PhD thesis, Technical University of Denmark (DTU).
- [3] Bechert S., Groenewolt A., Krieg O. D., Menges A., and Knippers J. Structural Performance of Construction Systems for Segmented Timber Shell Structures. *Proceedings of IASS Annual Symposia*. Vol. 2018. No. 20. International Association for Shell and Spatial Structures (IASS), 2018.
- [4] Block Research Group. eEQUILIBRIUM: an interactive, graphic statics-based learning platform for structural design, https://block.arch.ethz.ch/equilibrium/cases/waterloo_vs_berlin (accessed on: 12 april 2021)
- [5] Douthe C., Mesnil R., Orts H., and Baverel O. Isoradial meshes: Covering elastic gridshells with planar facets. *Automation in Construction*, 2017, 83, 222-236. <https://doi.org/10.1016/j.autcon.2017.08.015>
- [6] Engelsmann S., Spalding V., and Peters S. *Plastics: in architecture and construction*. Walter de Gruyter, 2012.

- [7] Grande E., Imbimbo M., and Tomei V. Structural optimization of grid shells: Design parameters and combined strategies. *Journal of Architectural Engineering*, 2018, 24(1), 04017027. [https://doi.org/10.1061/\(ASCE\)AE.1943-5568.0000286](https://doi.org/10.1061/(ASCE)AE.1943-5568.0000286)
- [8] Gu L., and Togay O. Use of recycled plastics in concrete: A critical review. *Waste Management*, 2016, 51: 19-42. <https://doi.org/10.1016/j.wasman.2016.03.005>
- [9] G+D Computing. *Straus7 User's Manual*. 2005.
- [10] Laccone F., Malomo L., Froli M., Cignoni P., Pietroni N. Automatic Design of Cable-Tensioned Glass Shells. *Computer Graphics Forum*, 2019. <https://doi.org/10.1111/cgf.13801>
- [11] Miu E. V., Fox A. J., Jubb S. H., and Wakabayashi K. Morphology and toughness enhancements in recycled high-density polyethylene (rHDPE) via solid-state shear pulverization (SSSP) and solid-state/melt extrusion (SSME). *Journal of Applied Polymer Science*, 2016, 133(10). <https://doi.org/10.1002/app.43070>
- [12] Pattanakul C., Selke S., Lai C., and Miltz J. Properties of recycled high density polyethylene from milk bottles. *Journal of Applied Polymer Science*, 1991, 43(11), 2147-2150. <https://doi.org/10.1002/app.1991.070431122>
- [13] Pellis D., Pottmann H. Aligning principal stress and curvature directions. *Advances in Architectural Geometry*, 2018.
- [14] Preisinger C. and Heimrath M. Karamba - A Toolkit for Parametric Structural Design. *Structural Engineering International*, 2014, 24:2, 217-221. <https://doi.org/10.2749/101686614X13830790993483>
- [15] Rad A. R., Burton H., Rogeau N., Vestartas P., and Weinand Y. A framework to automate the design of digitally-fabricated timber plate structures. *Computers & Structures*, 2021, 244, 106456. <https://doi.org/10.1016/j.compstruc.2020.106456>
- [16] Rajendran S., Scelsi L., Hodzic A., Soutis C. and Al-Maadeed, M. A. Environmental impact assessment of composites containing recycled plastics. *Resources, Conservation and Recycling*, 2012, 60, 131-139. <https://doi.org/10.1016/j.resconrec.2011.11.006>
- [17] Ramírez-Vargas E., Sandoval-Arellano Z., Hernández-Valdez J. S., Martínez-Colunga J. G., and Sánchez-Valdés S. Compatibility of HDPE/postconsumer HDPE blends using compatibilizing agents. *Journal of Applied Polymer Science*, 2006, 100(5), 3696-3706. <https://doi.org/10.1002/app.23214>
- [18] Robeller C., Konakovic M. A., Dedijer M., Pauly M., and Weinand Y. A double-layered timber plate shell-computational methods for assembly, prefabrication, and structural design. *Advances in Architectural Geometry* 2016, 2016, 5, 104-122.
- [19] R. McNeel Associates. Grasshopper generative modeling for Rhino, Computer software, <http://www.grasshopper3d.com> (2018).
- [20] Sonntag D., Aldinger L., Bechert S., Alvarez M., Groenewolt A., Krieg O. D., Wagner H. J., Knippers J., and Menges A. Lightweight segmented timber shell for the Bundesgartenschau 2019 in Heilbronn. *Proceedings of IASS Annual Symposia*. Vol. 2019. No. 26. International Association for Shell and Spatial Structures (IASS), 2019.
- [21] Todisco L., Peiretti H. C., and Mueller C. Funicularity through external posttensioning: design philosophy and computational tool. *Journal of Structural Engineering*, 2016, 142(2), 04015141. [https://doi.org/10.1061/\(ASCE\)ST.1943-541X.0001416](https://doi.org/10.1061/(ASCE)ST.1943-541X.0001416)
- [22] Todisco L., Corres-Peiretti H., and Mueller C. Exploration of externally post-tensioned spatial structures using 3D graphic statics. In *Proceedings of IASS Annual Symposia* (Vol. 2018, No. 16, pp. 1-8). International Association for Shell and Spatial Structures (IASS), 2018.